



**Agilent E4467B
E4468B
E7792A**

Tie Together Kit
Fits Agilent 19-inch EIA Cabinets

Installation Instructions



Notice

The information contained in this document is subject to change without notice.

AGILENT TECHNOLOGIES MAKES NO WARRANTY OF ANY KIND WITH REGARD TO THIS MATERIAL, INCLUDING, BUT NOT LIMITED TO, THE IMPLIED WARRANTIES OF MERCHANTABILITY AND FITNESS FOR A PARTICULAR PURPOSE.

Agilent Technologies shall not be liable for errors contained herein or for incidental or consequential damages in connection with the furnishing, performance, or use of this material. This document contains proprietary information, which is protected by copyright. All rights are reserved. No part of this document may be photocopied, reproduced, or translated into another language without the prior written consent of Agilent Technologies.

Copyright © 1998, 2001 Agilent Technologies, Inc.

General Information

The tie-together kit connects two Agilent Technologies instrument cabinets side-to-side. This document provides all information required to install the tie-together kit. It also describes how to remount the doors on two tied-together cabinets so that they both swing open from the center. To accommodate all cabinet sizes, Agilent offers the tie-together kit in four models:

Part Number	Description	Applicable Rack Model
E4467B	1300 mm Tie Kit	E7590A
E4468B	1600 mm Tie Kit	E3661B
E7792A	2000 mm Tie Kit	E3662B

Contents

The tie-together kit contains the following items:

Qty	Description	Rack Model	Part Number
1	Tie top	All	E3661-00011
1	Tie-Rear -- 1300 mm	E7590A	E3905-00008
	Tie-Rear -- 1600 mm	E3661B	E3661-00013
	Tie-Rear -- 2000 mm	E3662B	E3662-00009
1	Tie-Front -- 1300 mm	E7590A	E3905-00009
	Tie-Front -- 1600 mm	E3661B	E3661-00012
	Tie-Front -- 2000 mm	E3662B	E3662-00008
1	Door Stop Assembly	All	E3661-60013
6	Bolt-Hex 1/4" -20 x 3	All	0570-0069
6	Washer-Lock Ext T, 1/4"	All	2190-0382
6	Nut-Hex, Double Chamfer 1/4" - 20	All	2950-0031
2	Screw, Machine, TORX T25-10- 32 x 0.5"	All	2680-0278
2	Stiffener, Hinge	As needed	5061-8746

Note: Part numbers are listed for reference use only. These parts are not set up as replacement parts. For kit content errors, contact your local Agilent Sales Representative.

Tools Needed

To install the tie-together kit, you need these tools:

- T25 Torx driver (included with the cabinet)
- Socket Wrenches
- Level (recommended)

Installation Time

A standard installation takes about one hour.

Cabinets are configured so that the rear doors (and optional front doors) both open from the right.

You can remount the doors on the tied-together cabinets so that they swing open from the center. (The door on the right-hand cabinet opens from the left, not the right.) If you choose this option, allow an additional hour for the tie-together installation.

Installation Procedure

The following procedure tells how to tie together two cabinets with the tie-together kit:

Note	Extend the cabinet's anti-tip stabilizer before moving any components forward out of the cabinet on their slides. See Figure 1.
-------------	---

1. Remove items from the cabinets that could interfere with installation of the tie-together kit.
 - If one or both cabinets currently hold equipment, remove all equipment and shelves that may block the cabinet-column holes needed by the tie-together kit.
 - If the cabinets are empty and were just unpacked, find and remove the four shipping panels inside the cabinet enclosures. See Figure 1.

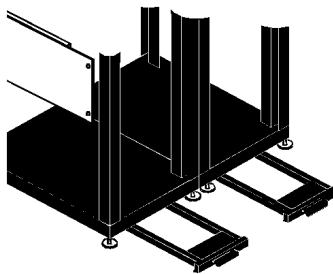

Figure 1. Cabinet Shipping Panels and Anti-Tip Foot

2. Remove side panels that will not be needed when the two cabinets are tied together.
 - Remove the right side panel from Cabinet 1. (See Figure 1). Remove the two screws at the base of the side panel. Open the rear door and loosen the panel clamp on the door hinges. Grasp the sides of the side panel and pull the bottom of the panel away from the cabinet slightly. Then lift up and away.
 - Remove the left side panel from Cabinet 2. (See Figure 2.) Follow the same procedure as for Panel 1, except that there is no panel clamp to loosen.

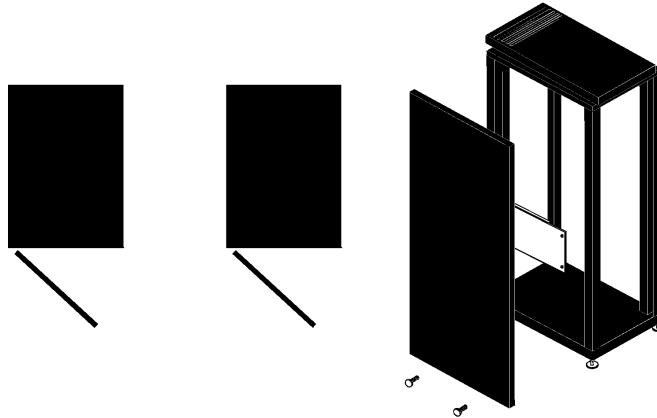

Figure 2. Removing Side Panels from the Racks

Note If you are installing Agilent NetServers and their peripherals in the cabinets, remove both side panels from each cabinet. Also remove the rear doors. For more information, read the NetServer's Rack Installation Roadmap.

3. If you decide to remove the rear doors, disconnect the grounding wire from each door. Then slide the lower spring-loaded hinge pins into the open position (in toward the center) and lock in place. Hold the door in place and repeat with the upper pins.
4. Decide how the rear doors (and front doors, if present) should be mounted: so that both doors open from the right (the default), or that they swing open from the center. If you want center-opening doors, remount the hinges and latch catches as described in the next inside hinges which are no longer supported by the side panel. (See Figure 3.)

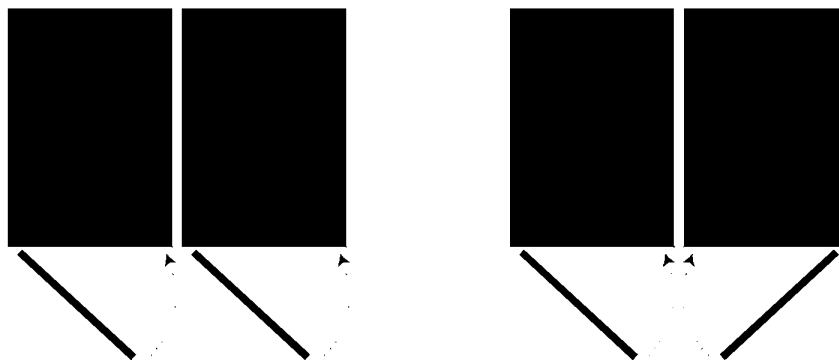

Figure 3. Alternate Configurations for Rear Doors

5. Position the two cabinets next to each other, about three inches apart. (See Figure 4)
6. Put the L-shaped tie-top panel in place between the two cabinets. The tie-top has tabs that slip into slots on top of each cabinet. (See Figure 4)

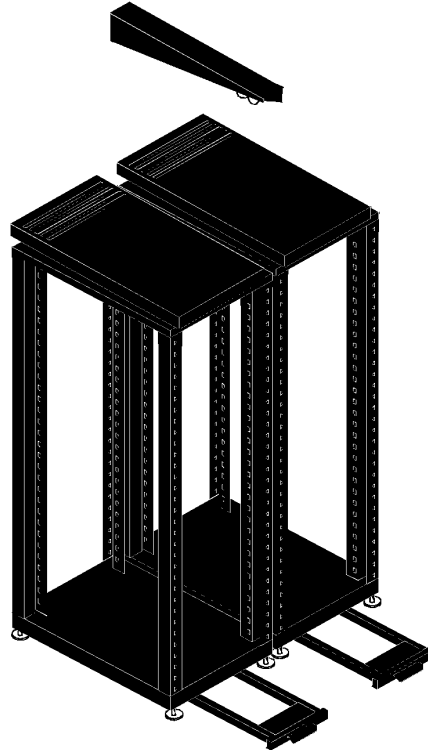

Figure 4. Attaching the Tie Top Panel

Note Make sure that the cabinet enclosures are on a level surface, so that the holes in the cabinet columns align. If you cannot find a completely level surface, adjust the cabinet levelers so that the cabinets are level and holes align. Place a level across the top of the cabinets to make sure are level with another, both side-to-side and front-to-back.

7. Place the tie-front panel between the front columns of the two cabinets. Make sure that the top tab goes over the lip of the tie-top. Fasten the panel in place with three bolts, as shown in Figure 5. Leave the nuts loose for now.

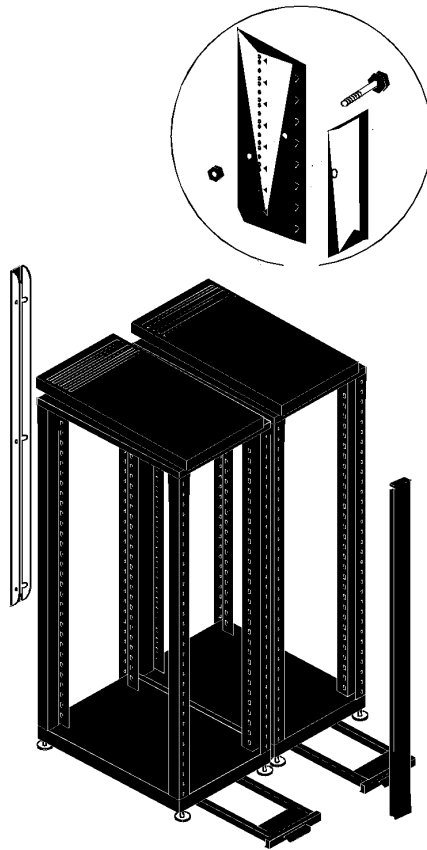

Figure 5. Attaching the Tie Front and Tie Rear Panels

8. Screw the door-stop bracket onto the rear-tie piece. Screws attach from the inner surface of the rear tie and screw into the door stop. See Figure 6.

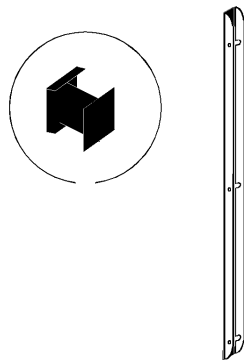

Figure 6. Attaching the Door Stop Bracket

9. Press the tie-rear insert into place between the rear columns of the two cabinets. Fasten the panel in place with three bolts, as shown in Figure 5. Leave the nuts loose for now.

10. Use a level to make sure that the cabinets line up with each other precisely. Adjust the racks' position as necessary, and then tighten the nuts on the bolts that fasten the front and rear ties in place.
11. Install (or reinstall) equipment and shelves in the cabinet.
12. Reinstall rear doors and outer side panels, if removed. If the cabinets have front doors, reinstall them also.

Remounting Doors to Open from the Center

In the standard configuration, a cabinet's rear (and front) doors open from the right. But you can remount the doors on two cabinets so that they swing open from the center when tied together—See Figure 3. (The door on the right-hand cabinet will open from the left, not the right.) To do this, you must follow a special tie-together installation procedure. This section describes the steps you must follow.

Prepare Rack and Remove Rear Door From Rack 2

1. Perform steps 1 and 2 of the tie-together installation procedure in the previous section.

Note

Extend the cabinet's anti-tip stabilizer before moving any components forward out of the cabinet on their slides.

2. Remove the rear door from Rack 2.
3. Remove the rear door hinges from the left rear column of Rack 2. (For the upper hinge, you must loosen the clamp that holds it to the side panel.)
4. Once you have removed the hinges, remount them on the right-rear column. Mount the hinges on the outer (non-EIA) holes: at the third and fifth hole from the top of the column, and at the seventh and ninth hole from the bottom.
5. Remove the latch bracket from the right-rear column. Note its position. Reinstall it on the left rear column at the same position. This is done by moving the sheet metal nuts to the left column and fastening the latch with TORX screws.

Remove PDUs from Rack 2

6. If Rack 2 already has power distribution units (PDUs) installed, you must move it from the right side to the left side of the cabinet (facing from the rear). Remove the top cap of Rack. The cap is held in place by two screws at the top rear of the cabinet. Remove the screws, then slip the cap back a few inches and lift it off the cabinet. Save the screws for later reinstallation.
7. Unplug the extractor fan (if so equipped) and all other equipment from the PDU(s).
8. Remove the grounding wire(s) from the PDU(s) to the cabinet frame.
9. Remove the PDU(s) from the cabinet brackets. Each PDU is held in place by two screws: one each for the top and bottom brackets. Save the screw(s) for later use.

10. Remove the PDU brackets from the right rear column. Note the position of the brackets. You will reinstall them at the same position on the left column later. Save the sheet metal nuts (two per bracket) and four screws for later use.

Install Tie Kit

11. Install the Tie Kit. Follow the installation procedure in the previous section, up to step 9.
12. Install the PDU brackets on the left-rear column of Rack 2. They should be at the same position as they were on the other column. Note that they must be inverted so they are oriented correctly, and are attached with screws and sheet metal nuts (two each per bracket).
13. Install the PDU(s) onto the brackets. The PDU(s) are held in place by two screws: one on each for the top and bottom brackets.
14. Install the grounding wire(s) from the PDU(s) to the cabinet frame with screws and nuts saved from Step 10 of this procedure.

Warning You must reconnect the PDU grounding wire to prevent electrical hazard in the event of a short or other malfunction.

15. Route the extractor fan cord (if so equipped) along the top of the cabinet and plug it into the top receptacle. Note that you can conceal the cord by routing it up through the access slot at the top of the cabinet and behind the extractor fan unit. If you choose to do this, you will need to use an IEC-320 power cord (supplied with some localization options) because the extractor fan cord is not long enough. IEC-320 cords can be ordered via P/N 8120-1575C. To route the cord, the extractor fan must be removed.
16. Replace the top cap. Slide the top cap into position and secure it with the retaining screw.
17. Reinstall any equipment that was removed from the cabinet. If the cabinet was empty to begin with, install equipment now.
18. Reinstall outer panels on either side of the tied-together cabinet.
19. Reinstall the rear door.
20. Attach the ground wire to the rear door and ground post located next to the right rear column.
21. Retract the anti-tip stabilizer bars.